

Network Video Systems

A full line-up of monitoring cameras to select from for your purpose, application, and installation location.

Network cameras to meet the ever-increasing requirements for security and safety



- Shopping areas, schools, apartment
- Financial institutions, supermarkets, and convenience stores
- Shops, public facilities, hospitals, tourists spots
- Office building entry/exit points, train stations, research laboratories, and highways
- Factories, parking lots, warehouses, night deposit drops, and parks
- Plants, power stations, shipping centers, refuse incineration plants

Making use of a wireless LAN, it is easy to configure a video distribution system.

Wireless LAN Connection Example

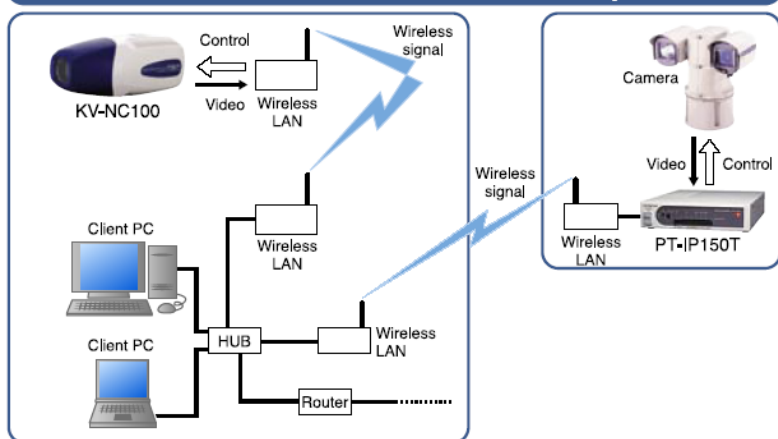

It is also possible, using optical fiber, to configure a personal computer live surveillance system for monitoring over a large area.

Optical Fiber Cable Connection Example

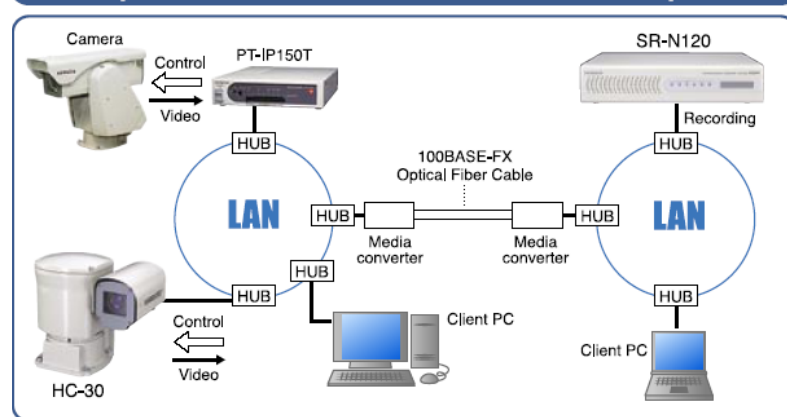

Dome-type Network Camera
KV-IP13



For store, public facility, hospital, and tourist spot applications.

- Stylish sunken designs avoid disturbing appearance, and provide broad monitoring capabilities without sacrificing a store's image.
- A highly shock-resistant polycarbonate dome cover and rugged die-cast aluminum housing provide not only attractive appearance, but also strength.

Multifunction Network Camera
KV-NC100



For parking lots, office building entry/exit points, and train stations.

- Intelligent Camera with Image Processing Capability.
- Features motion detection capability.
- Settings and changes are done by easy operations.
- Built-in temporary screen storage.
- 24-Hour cameras on-the-job day and night.

Network Digital Recorder
SR-N120



Recording of images from Hitachi network devices.

- Powerful recording functions.
360 frames/s recording of standard images and 120 frames/s recording even with high-resolution images.
- Use of a standard browser eliminates the need for special software.
- Long-term recording using a large-capacity (250 GB) hard-disk drive.
- Digital control provides such convenient functions as timed detection and alarm searching for further enhancement of operational ease.

Main Operating Screens of the SR-N120

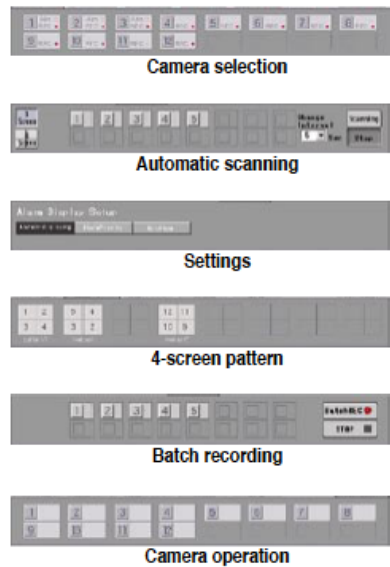

CAUTION : To ensure safe operation, please read the instruction manual before using this product.

These Specifications are subject to change without notice.

Hitachi Kokusai Electric Inc.

Head Office
14-20, Higashi-Nakano 3-choume, Nakano-ku, Tokyo 164-8511, Japan
Phone: +81 (0) 3-3368-6111, Fax: +81 (0) 3-3365-9119
URL: <http://www.h-kokusai.tv>
Hitachi Kokusai Electric Inc. Beijing Office
Beijing Fortune Building5, Dong San Huan Bei - lu, Chao Yang District, Beijing, China
Phone : 86-10-6590-8755/8756

